

Maximizing Auto Part Productivity with Advanced Intelligent Systems

Test and Measurement Technology for Quality Assurance

- Automobile Industry Overview
- Core Technologies
- Applications
- Complete Product Lineup

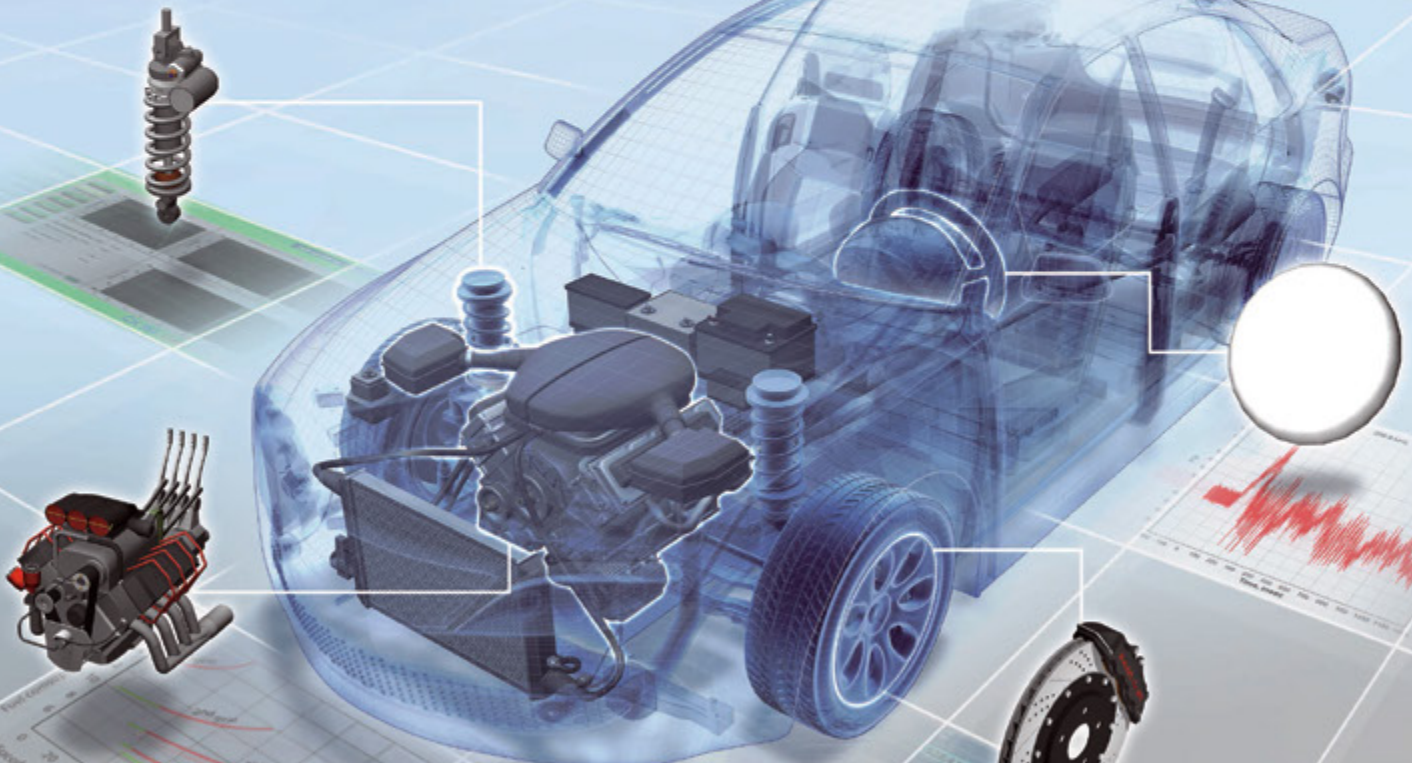

ADVANTECH

Enabling an Intelligent Planet

www.advantech.tw

Industry Overview

Identifying and Seizing High-Growth Opportunities

In 2014, approximately 71 million automobiles were sold worldwide, an increase of 3.4% from 2013. IHS, an international research organization for authoritative reference content, has boldly predicted that the global automobile market will maintain this trend of stable growth until 2018. By which time, annual global automobile sales could reach as high as 100 million units. In recent years, despite the European economy facing numerous challenges with the potential to impact sales, increased demand for household vehicles in other developing and emerging regions, such as China, India, and Eastern Europe, continues to drive strong growth in the automobile market.

Automobile manufacturers are keen to expand their share of the increasingly affluent Asian market, where sales of passenger vehicles have doubled in the last 7 years. In Malaysia, Indonesia, and India, automobile sales figures have shown consistent growth. In China, the enormous demand for automobiles resulting from rising per capita income has increased sales of passenger vehicles by 200% since 2010, reaching a staggering 23 million units. China has also become the number one producer of light-duty vehicles. Additionally, the steady decline in oil prices during 2014 yielded a positive, if short-term, impact on the automotive market. Lower oil prices also stimulated vehicle sales in mature markets like the United States, enabling automobile manufacturers to achieve record growth in the second half of 2014. Considering all the relevant factors, the global automotive industry should be able to maintain a steady growth trend over the next 5 to 10 years.

The Challenges of Globalization

To increase revenue, vehicle manufacturers are striving to sell competitively priced high-quality products in the global market, while also developing domestic markets. With the ongoing advancements in manufacturing technologies and automobile development, major automotive brands have accumulated considerable technological capabilities to compete with international automobile manufacturers. However, increasingly high tariff barriers and stringent environmental regulations continue to pose substantial challenges for automobile manufacturers.

As environmental awareness soars, carbon emission limits have become a key factor that determines whether a vehicle can be sold in the global market. The tire labeling regulations implemented by the European Union in 2012 provide an example of manufacturing and grading standards that relate to vehicle carbon emissions. The countries of Japan, South Korea, and the United States have also implemented a similar tire grading system. In response to this trend, part and component suppliers for leading automobile manufacturers must adopt more comprehensive high-precision production, design, and testing equipment to ensure that products comply with relevant regulations.

Industrial Equipment Upgrades are Critical

In recent years, malfunctioning components have led to high-profile accidents and safety risks, resulting in numerous large-scale product recalls by automobile manufacturers. Massive product recalls significantly affect a company's bottom line and may even cause future losses by damaging the brand value. The implementation of high-precision production and assembly equipment can prevent such losses. The modernization and automation of plant equipment are critical advancements that automobile manufacturers and component suppliers must wholeheartedly pursue. Parts built using precision machinery are significantly more reliable than those made using more traditional processes. Advantech's industrial I/O cards are the keys to such technological enhancements. From flexible plug-and-play USB data expansion/acquisition modules to high-efficiency, high-precision PCI and PCIe cards, Advantech's quality products and comprehensive product line can provide solutions for all application demands.



Smart Manufacturing Will Increase Competitive Advantages

Since Germany proposed the Industry 4.0 concept in 2012, smart factories have become a popular topic for manufacturers worldwide. Through the integration of information and realization of the Internet of Things, all the machinery, equipment, and components in factories of the future will be able to instantly exchange information or even control each other, significantly upgrading production efficiency, speed, and flexibility. For the automobile industry, future developments will continue in pursuit of intelligent solutions, electrification, lightweight products, and modularization. Meanwhile, the ratio of common components shared by various automobile manufacturers will gradually increase.

With upgrades in production technology, high-quality parts and components developed by one manufacturer will have a high likelihood of being adopted by other automobile brands. Consequently, the potential business opportunities for part manufacturers are no longer limited to local automobile producers. Part manufacturers can expand internationally, benefit economically from the global market, and further reduce production costs while achieving higher profits. Advantech has responded quickly to recent trends, becoming one of the first manufacturers to embrace the Internet of Things. By providing comprehensive field-side product solutions, including data acquisition modules, boards, and high-performance computing platforms as well as SCADA software (WebAccess) for control terminals, Advantech is taking active steps to welcome in the new industrial era and substantially assist its partners with realizing smart manufacturing.

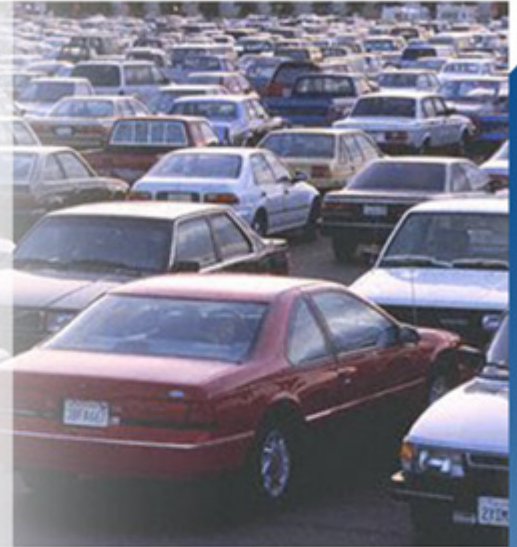

Advantech Product Solutions and Opportunities

■ DAQNav Data Acquisition Driver and Software Development Package

An automobile contains approximately 8,000 components, whose manufacturing processes differ according to the vehicle type and application. Therefore, such components require vastly different product safety tests. Advantech's next-generation data acquisition driver and software development package, DAQNav, is designed to handle the unique aspects of testing, measurement, and development operations. For example, DAQNav supports multiple programming languages and operating systems, can be used under multi-threaded and multi-core execution environments, and features an easy-to-operate interface. This enables test system developers to focus on their areas of expertise without worrying about system-related programs and cross-platform compatibility issues. This free software package contains device drivers and a complete SDK that includes libraries, sample codes, and general programs, enabling developers to customize programs according to specific manufacturing processes.

DAQNav



■ Industrial Computers

Advantech produces a full range of industrial computers for diverse applications in the automation field. By offering extensive system integration services, including customization, integration, validation, and certification, Advantech demonstrates its commitment to providing customers with all-in-one solutions and rugged systems that maximize their capabilities and productivity.



■ High-Performance Instrument Cards

Advantech's new generation of instrument cards can provide either a 500-MHz data acquisition rate or 24-bit ultra-high resolution measurement functions. The ultra-high-speed 500-MHz data acquisition card integrates four channels and features 2 GB of built-in memory. The 500-MHz sampling rate enables the card to process up to 1 GB per second. Using Advantech's specially developed RAID platform, the card can collect data continuously for 2 hours. The 24-bit ultra-high resolution card can be used to measure subtle vibrations and sound frequencies via integrated piezoelectric sensors (4/20mA) to provide accurate data for producing vehicle safety-related precision parts, such as gearboxes and engines. The two cards possess analog signal trigger functions, essential for routine machine inspections and real-time data acquisition, and can significantly shorten the signal analysis period.





Portable USB Data Acquisition Module

The USB-4700 Series DAQ module is compact, easy to carry, and features a USB plug-and-play interface. With just a notebook computer, production line engineers can collect data from each workstation at any time. The process is fast and convenient and not constrained by environment. During product design validation, the module can also be used as secondary measurement equipment to enhance the accuracy of test measurements.



Next-Generation Rugged Industrial Computers

The 2G anti-vibration capacity of Advantech's MIC-3100 rugged industrial computers makes these systems suitable for tire or transmission performance testing. This type of testing equipment must be continually activated; however, vibrations during testing can significantly affect the accuracy and operations of traditional industrial PCs. Advantech's MIC-3100 series is equipped with excellent shock resistance capabilities, and the inclusion of a CPCI interface provides vibration resistance. Integrated with an expansion box, MIC-3100 can support CPCI and PCI interfaces, as well as various types of measurement cards. The system also supports hot-swapping for convenient test card exchanges.



PCIE/PCI High-Speed Data Acquisition Cards

Advantech produces comprehensive digital and analog I/O solutions in both PCIE and PCI interface formats, and its products can support many of the sensors and platforms used in manufacturing and testing automobile parts. Regarding digital I/O cards, Advantech provides complete solutions that range from TTL, isolated signal circuits, to relay modules, with a variable number of signal channels (16 to 128). The analog I/O series provides acquisition modules with up to 32 channels. Synchronous cards with a 500MHz sampling rate and multifunction cards with digital I/O provide reliable data acquisition capabilities for diverse applications, such as high-pressure cylinder testing for airbag inflation.



Case Studies

Automobile Brake Testing System

Project Description

The braking system plays a pivotal role in driving safety. Therefore, products related to braking are subjected to extremely high intensity and rigorous tests during the brake component production process in order to ensure normal function under all conditions. With advanced automobile brake detection devices as well as precision measurement and sensing technologies, automobile brake test platforms can perform brake equipment tests for a variety of vehicle types. All of the test methods are controlled and inspected using torque sensors and servo motors. For these tasks, the analog and digital mass data acquisition cards adopted by Advantech's industrial computers can seamlessly link the actual on-site data with the standard data. This system uses a PC-based structure and applies data acquisition and signal processing, industrial control and automation as well as database and computer monitoring techniques.

System Requirements

- 1 · The industrial computer must withstand 8 hours of continuous operation without stopping in order to perform brake fatigue tests.
- 2 · Compact industrial computer system with 2 PCI slots for space saving.
- 3 · System hardware stability is essential because the brake safety system must satisfy strict national standards.
- 4 · Settings perform multiple parameters under multiple conditions.

System Functionality

This testing system examines the brake capacity efficiency by measuring the brake pedal's stepping stroke and the corresponding brake force. The 800 KS/s high-speed sampling capability and the 12-bit ultra-high resolution can enable the PCIE-1810 to accurately capture the brake resistance of the tires, while the PCI-1784 count card can synchronously record the stepping stroke of the brake pedal. In conjunction, they plot an intensity diagram that illustrates the amount of force applied to the tire for each unit of stepping stroke applied to the brake pedal, and thereby analyze the actuation efficiency of the braking system.

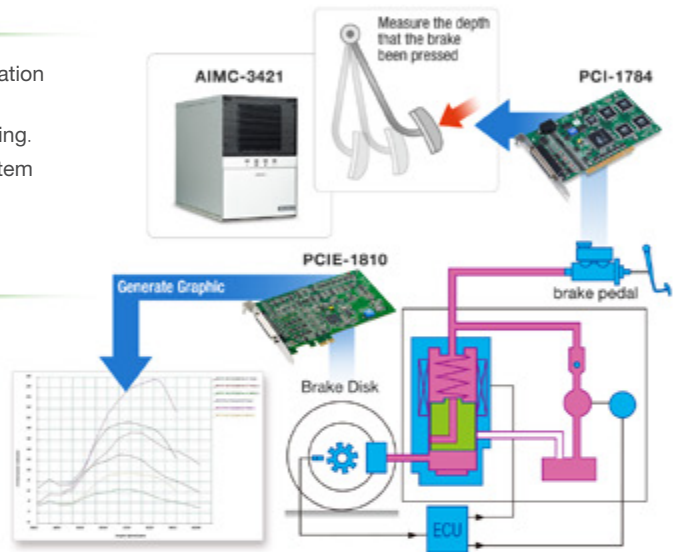

Vehicle Shock Absorber Automatic Test System

Project Description

The shock absorber suspension system is a critical component of a car, and its performance directly affects the car's handling safety and comfort. Shock absorber malfunctions can affect an automobile's stability and also have a direct and critical impact on the active safety of the vehicle. Therefore, the operational status of the absorber is absolutely essential to driving safety. This system can test the damping features and power characteristics of shock absorbers, reduce the shock absorber test cycles and improve efficiency.

System Requirements

- 1 · The sine and cosine noise wave generators have been designed to test the damping, speed, and displacement characteristics of the automobile shock absorbers.
- 2 · It uses simulated signal fitting, differentiation, and filtering processes to observe the dynamometer and speed curves.
- 3 · Damping force signals are monitored and spectrum analysis is performed in order to determine whether the shock absorber passes the test.
- 4 · Data storage and replay functions.

System Functionality

- 1 · The 500K/S sampling rate and 16-bit resolution of the PCIE-1816 data acquisition card can accurately collect the damping force changes captured by the pull/pressure force sensors. In addition, the absorber's displacement variations can be changed into voltage signals through the differential transformer displacement sensors, and finally collected.
- 2 · ARK-5261 is a fanless box PC, Its 5G seismic resistance capacity can fully adapt to the rocking motions produced by the shock-absorber testing machine's operations.

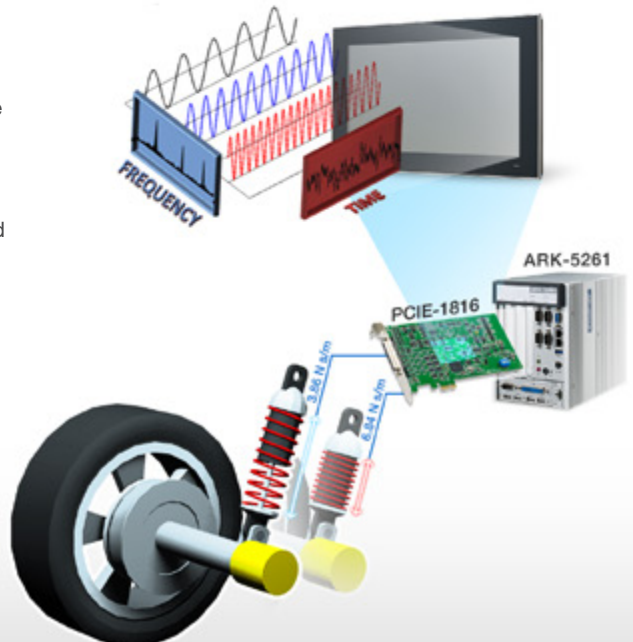

Tire Fatigue Performance Test System

Project Description

Fatigue breakdown is the primary failure method for car wheels and is directly related to passenger safety. The bending fatigue strength is an important parameter used to describe this condition. In this case sample, the microprocessor-controlled car wheel bending fatigue automatic test system is used to achieve real time monitoring, control, and display while maintaining the stability of the bending moment during the test process. The testing machine determines whether the wheel has passed the test by monitoring the changes to rotation numbers, and issues an alarm due to wheel fatigue before a breakdown occurs. Wheels are one of the most critical core components of a car and directly affect the safety and comfort level of the car. The process to manufacture wheels includes stamping, forming, welding, and anti-corrosion treatment. The requirements for each process are extremely stringent. From the perspective of actual operation, the force absorbent surfaces of a car's wheels are extremely complex when the car is being driven. In addition to the support, lateral, bending moment, and driving forces, as the wheels rotate and withstand friction, the temperature and pressure can also change at any time. Therefore, the fundamental issue of the wheel design and manufacturing process is to ensure that the fatigue lifespan can satisfy the application and performance requirements.

System Requirements

Typically, wheel fatigue lifespan tests and inspections include two aspects: The wheel radial fatigue test, which primarily inspects the comprehensive strength of the entire wheel, and the wheel bending fatigue test, which examines the wheel spoke and weld strengths. At present, the domestic automobile industry mostly uses imported hydraulic servo fatigue testing machines to perform tests on finished tire products. However, despite their high test accuracy, these machines are bulky and expensive, the tires being tested are hard to install during the testing process, and they lack test speed efficiency. Therefore, it is absolutely necessary to produce a highly efficient, affordable, and easy to install platform that does not sacrifice the accuracy of the test results for the manufacturers.

- 1 · Range of the primary wheel shaft rotation speed test:
40 to 400 rotations/minute.
- 2 · Pressure load test range: 0 to 70 kN.
- 3 · Highly efficient, anti-vibration computing platform.
- 4 · Machine layout is reasonable, compact, and easy to maintain.

System Functionality

Because this testing system must be operated over long periods of time and the wheel being tested will continue to rotate while the pressurized tests are being performed during the wheel testing process, machine vibrations end up as one of the factors that must be overcome. Therefore, Advantech's MIC-7500, equipped with 6th generation Intel® Core™ i processor and innovatively modular design, is suited for such systems. This fanless industrial PC has an integrated design that can be compatible with different expansion modules. The compact structural design of this system can also resolve the bulky and inconvenient installation problems accompanying the traditional machines. The PCIE-1810 multifunction data acquisition board, with a 800 kS/s sampling rate and 12-bit high resolution, can fully satisfy the wheel rotation speed and pressurized force measurement requirements.

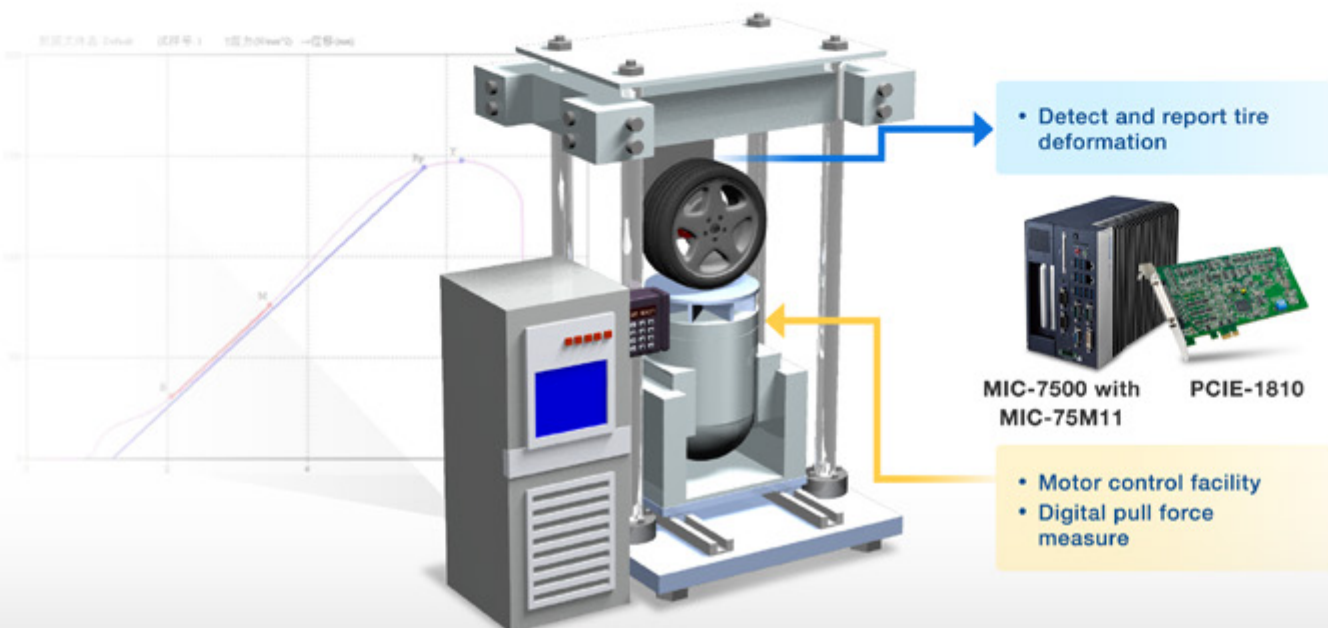

Case Studies

High-Speed Data Acquisition Clutch Performance Test System

Project Description

The clutch pedal is an important component within a vehicle's transmission system and directly affects the performance of the vehicle. The industry standard QC/T 27-2004 is typically used to perform the overall function as well as clutch durability and reliability characteristic tests. However, the price for the equipment needed to perform this test is very high, because of the high data accuracy requirements and the ultra-stringent data reliability standards. Maintenance for such high precision equipment is also much more difficult. Therefore, a portable and low cost clutch feature analyses system that can be used in real vehicle test environments is essential.

This system can measure and analyze the clutch pedal mechanics and location characteristics, time-domain characteristics, and separation actions, thus resolving the shortcomings of the traditional systems that can only perform the tests based on the independent parameters of the clutch or the pedal. The high-speed USB data acquisition module can perform high-precision tests, and its simultaneous multi-parameter real vehicle test capability can significantly improve test efficiency.

System Requirements

In terms of the clutch characteristic detection test, we can use a variety of characteristic parameters to analyze the power transmission performance of the clutch pedal being tested, and appropriately evaluate whether the pedal complies with the production standards. To maximize ease of installation and removal as well as the convenience of system construction, this system uses Advantech's USB series high-speed data acquisition module to record the data in real-time collected by the pressure and displacement sensors, which is used as the basis to analyze the following seven key areas:

- 1 · Maximum resistance during the pedal stroke process.
- 2 · Maximum pedal stroke.
- 3 · Free pedal stroke.
- 4 · Clutch contact point.
- 5 · Clutch synchronization point.
- 6 · Pedal force hysteresis.
- 7 · System efficiency.

System Functionality

For this project, the USB-4711 data acquisition module was equipped with 16 route 12-bit simulated volume input channels and 8 route DIO channels for a sampling rate of up to 100Ks/S, far higher than the required 60Ks/S. All data is collected using ACP-2010, a 2U rackmount chassis, and AIMB-705, a 6th generation Intel® Core™ i motherboard, to enable data analysis. FPM-7211W was also deployed for visualization and monitoring.

This USB 2.0 high-speed test system can provide substantial data to support clutch design improvements and is a breakthrough from previous models that could only test the characteristic parameters of a single clutch or pedal. This system boasts real-time responses, high scalability, and comprehensive functions. Additionally, the convenient plug-and-play design makes this system a highly flexible product design tool for clutch or transmission manufacturers.

Friction Clutch Mechanical Principle

Before pedal is pressed

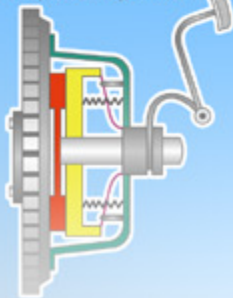

After pedal is pressed

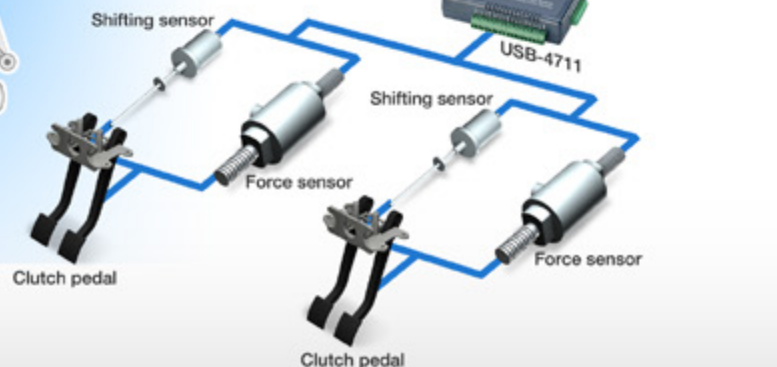
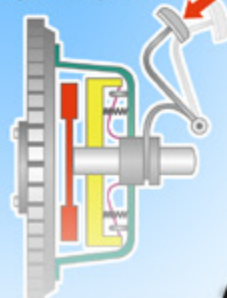

Automobile Transmission Test System

Project Description

A vehicle's actual application conditions, such as startup, idle park, low speed or high speed driving, speed increase, speed decrease, climbing, and reversing are extremely complex. They require the vehicle's driving force and speed to change within a large range. The range of output torque and speed change produced by the piston engines that are widely adopted at present is smaller. In order to adapt to the constantly changing driving conditions and to enable the engine to work under favorable conditions (higher power with lower fuel consumption), a gearbox is added into the transmission system. The automobile gearbox is one of the highest-tech products among the components for a vehicle. One of its more crucial aspects is online testing, which aims to simulate the car's actual operating conditions while on the production line to test for transmission related indicators.

System Requirements

At present, the automotive transmission detection scheme primarily comprises using a generator analog engine and generator analog load methods to achieve the online testing functions. The specific procedures are as follows: Use two AC motors to simulate vehicle conditions and detect the transmission's integrated indicators online. During each stage of the shift change process, the load capacity can be used to instantly monitor the system's operating parameters and plot out the system performance curve. The robotic arm automatically completes the different gear shift actions for different types of transmissions. Control the software's system operating parameters and record them immediately, provide real-time monitoring for temperature, speed, torque, and current, and provide automatic alarm and analyses when faults are encountered. The core of the control department is the computers. The control software are used to control the system's process, task allocation, instruction transmission, fault detections, etc., according to the field data and current operating conditions.

The automobile transmission detection system requirements are as follows:

- 1 · The machine will remain in a long-term vibrating state because of the engine running tests. Therefore, the computer must have an excellent shock resistance platform.
- 2 · High I/O expansion flexibility.
- 3 · Must be able to achieve instant control of the temperature, rotation speed, torque, noise, speed, and other status parameters.
- 4 · The system must be able to adapt to the plant's stringent requirements such as vibration, oil, dust, and continuous production.

System Functionality

The system adopts Advantech's rugged 7-slot modular industrial computer MIC-3111. Its MIC-3716 high-speed multifunction data acquisition card, 16-bit high-resolution, and 250 Ks/S ultra-high sampling rate can fully capture the transmission's operating parameters. Data such as temperature, rotation speed, torque, and noise are instantly displayed by the FPM-2150 industrial-grade touch screen display in the control room. In addition, MIC-3716 can be used to output the control parameters and achieve the gearbox loading, shift, and other operations. Meanwhile, the WebAccess configuration software can perform data logging and real-time monitoring on the operations of the entire test system, and can perform automatic alarm and analyses when faults are encountered.

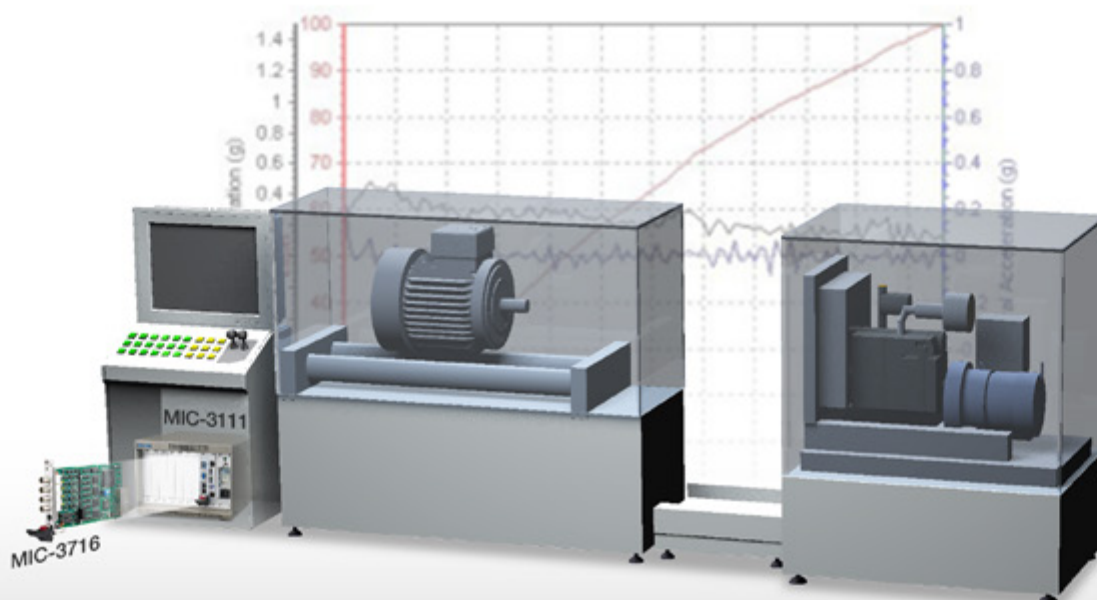

Case Studies

High-Pressure Cylinder Test for Airbag Inflation

Project Description

The principle of the airbags is that when a car is involved in a collision, compressed steel gas cylinders filled with gas rapidly inflate airbags in the center of the steering wheel and the side of the dashboard to reduce and prevent injuries of the driver and passengers. A high quality automotive airbag system cannot ignore the quality of the air reservoir cylinders, because once a cylinder bursts, the force of the high velocity gas may project cylinder fragments to the surrounding areas as well as people and cause significant injuries. Nations worldwide have currently established standards associated with the manufacturing, quality, and testing of the high-pressure cylinders. Therefore, it is now absolutely necessary to use a professional automotive airbag high-pressure steel cylinder testing machine to conduct the relevant tests for the cylinders in order to ensure their quality and safety during the production process.

System Requirements

The various types of the steel cylinders must undergo the relevant cylinder verification tests during the manufacturing process. Among them, the two most important are the fatigue and burst tests.

- 1 · The fatigue test must be able to conduct continuous tests by automatically adding and reducing pressure by preconfigured amounts.
- 2 · The system must be able to record the testing data and calculate the relative pressure and time curves.

System Functionality

Advantech provides a series of products that can perform high-speed pressure and flow volume measurements as well as equipment control for this application case sample. Advantech's industrial-grade 4U rackmount IPC ACP-4320 chassis with AIMB-785, the 6th generation Intel® Core™ i motherboard is used in combination with the PCI-1710UL to perform rapid data acquisition; instantly display the information collected on the human-machine interface; and begin to perform analyses, recording, report generation, etc. In terms of obtaining accurate pressure data based on customer requirements, the PCI-1710UL equipped by the industrial-grade computer is a high-speed analog input card that can capture the changing pressure signals rapidly and continuously. Its 100Ks/S high-speed sampling rate and 12-bit high resolution can perform rapid data acquisition at the speed 100 times faster than that of a PLC. When the test machine performs the pressurization and decompression fatigue test ten-thousand-time for a steel cylinder, the PCI-1710UL has the sampling rate of ten thousand times per second through the machines pressure sensors. This can significantly enhance the sampling rate to capture the changing pressure signals rapidly and continuously, and thereby resolve the customers' PC/PLC system data distortion problems.

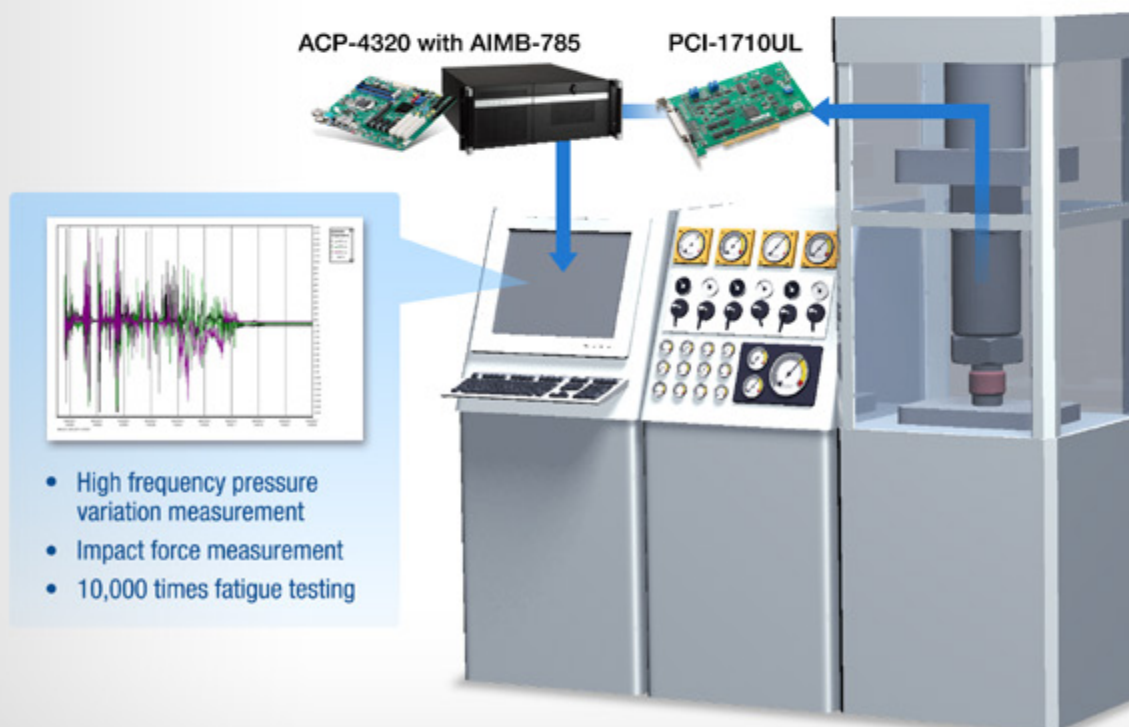

Vehicle Body Control Module Test System

Project Description

As automotive technologies progress, an increasingly wide range of vehicle body equipment must be controlled through the central console or the steering wheel while driving. To ensure that all equipment and dynamic performances operate normally when the vehicle is being driven, rigorous tests are required during the production phase to ensure the stability of the on/off switches as well as the actuation accuracies of the system. Fundamental test projects for this system include: wipers, door locks, windows, interior lighting, outdoor lighting, meters, safety, anti-theft vehicle stability assist system, etc. Because the standardized CAN bus protocol is adopted for the control units of the various body parts, Advantech provides the PCIE-1680 communication card that fully supports the CAN bus protocol to perform all of the on/off switch control tests for this testing field. The card is also equipped with DAQNav software which offers data acquisition and storage as well as automatic report generation functions that support the vehicle controller function and integrated vehicle tests.

System Requirements

- 1 · Manual tests: Use manual operation buttons to simulate the tests for the various switches and variables.
- 2 · Automatic function tests: Use the computer to control the various appliances and simulate the automatic tests for the various switches and variables. No human intervention is needed, resulting in improved testing efficiency.
- 3 · Add the simulated loads and actual loads to perform the test.
- 4 · Each sub-function test must be able to be performed under the various ignition states.
- 5 · During the test, a CAN bus can be used to diagnose the vehicle body controller configuration data to perform tests on the various functional configuration items.
- 6 · DAQNav can perform test data processing, display, and storage as well as automatically generate test reports.

System Functionality

Advantech's industrial 4U rackmount IPC and the PCIE-1680 dual channel CAN bus communication card are adopted. This card has high speed transmission efficiency of up to 1 Mbps and can play the role of a signal transmitter for vehicle body equipment test systems that pursue zero start/stop delays. Signal isolation protection is also adopted for a control element system that has complex wiring and a variety of start/stop arrangement combinations in order to provide undisturbed signal transmission, prevent operation errors, and improve system stability. This test system uses the primary CAN bus channel to perform signal communications between the host and the control elements, simulate the configuration of a finished vehicle, perform single/multiple device on/off switch load tests through control signals transmitted from the central machine, and then uses the DAQNav software to perform data recording and reliability analyses.

- Lighting system load simulation (turn signals, front fog lights, headlights, brake lights, etc.). Windows, wipers, door locks, and other loads
- The automobile meter test integrates a variety of vehicle buses. Its standard configuration is the CAN bus with the scalable FlexRay and LIN bus when needed by the test.
- Channel composite applications
- Provide specialized testing interfaces

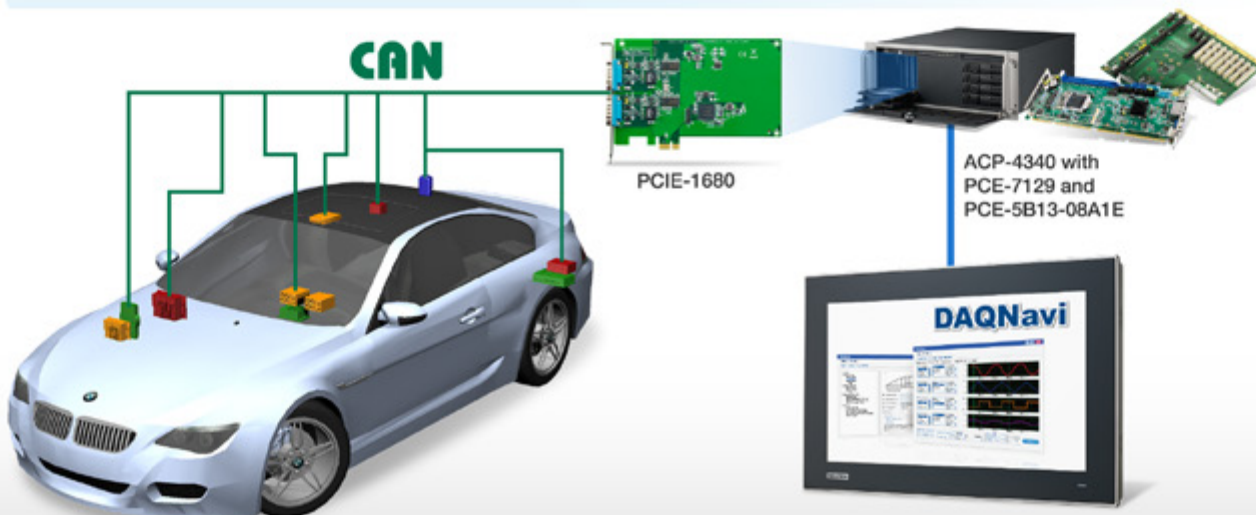

Comprehensive Range of Industrial Computers and Integration Services

Advantech delivers a full range of industrial computers for versatile applications in auto-part production. With sophisticated system integration services from customization, integration, validation, and certification a one-stop solution is our commitment in providing rugged systems to customers who require a trusted partner to maximize their application solutions.



Best-in-Class Benefits

- Flexible Configure-to-Order Services
- Global Certifications Ready
- Free 2-Year Global Warranty, Upgradeable to 5 Years
- Certified Peripherals for One-Stop Shopping

AIMC-3421

Micro Computer, Intel® Core™ i7/i5/i3 CPU, H81, 4 Expansions 2PCI/2PCIe, 300W 80Plus PSU

Features

- Intel® H81 Platform
- Intel® 4th gen Core™ i7/i5/i3 CPU (LGA1150)
- Two PCIe (x16/x1) & two PCI Expansion Slots
- Compact & Rich I/O Configuration
- One internal 3.5" SATA HDD bays with shock-resistant
- Optional front removable 2.5" HDD bay
- VGA, 2 GbE LAN, 4 USB2.0, 2 COM

OS Support



ARK-5261

Intel® Celeron® Processor J1900 Fanless Embedded BOX PC with PCI/PCIe Expansion and Dual Mobile HDDs/SSDs

Features

- Sealed construction with fanless operation
- Intel® Celeron® Processor J1900 up to 2.41 GHz
- Supports 2 Giga LAN and 1 USB 3.0 + 5 USB 2.0
- Support 4 RS-232/422/485 with Auto-flow control and COM 1 & 2 port with 5V/12V power
- Built-in 1 x PCIe, and 2 x PCI expansion slots or 3 x PCI expansion slots
- Support 4 RS-422/485 Isolation module type
- Rubber anti-vibration card-holder for PC expansion boards

OS Support



MIC-7500 with i-Module

6th Generation Intel® Core™ i Processor Compact Fanless System



Features

- Support 6th Generation Intel® Core™ i7/i5/i3 BGA type CPU with Intel® QM170 PCH
- Support VGA & DVI
- Support 1 x 2.5" HDD/1 x CFAST slot/1 x mSATA
- Support 2 Giga LAN and 8x USB 3.0
- Support 2 x RS-232/422/485 Serial & 2 x RS-232 (2 x RS-232 expansion by cable)
- Support Isolation COM module & 32bit GPIO module

OS Support



ACP-2010 with AIMB-705

6th Generation Intel® Core™ i 2U Rackmount System with up to 3 Expansions



ACP-2010

- Supports Micro-ATX/ATX motherboard
- LED indicators and audible alarm notification for system fault detection
- One 5.25" and three 3.5 Shock-resistant drive bays
- Various riser card options to support three full-size PCI or PCIe cards for expansion
- Supports 300W / 400W ATX PFC power supply

AIMB-705

- 6th Generation Intel® Core™ i7/i5/i3/Celeron/Pentium processor with H110 chipset
- Dual channel (Non-ECC) DDR4 1866/2133 up to 32GB
- Support VGA and DVI display
- Support SATA3.0, USB3.0, dual GbEs

OS Support



ACP-4320 with AIMB-785

6th Generation Intel® Core™ i 4U Rackmount System with up to 7 Expansions



ACP-4320

- Supports ATX motherboard or PICMG backplane with up to 15 slots
- Support dual SAS/SATA hot-swap HDD trays
- LED indicators and alarm notification for system fault detection
- Low noise system fans

AIMB-785

- 6th Generation Intel® Core™ i7/i5/i3/Celeron/Pentium processor with Q170 chipset
- Dual channel (Non-ECC) DDR4 1866/2133 up to 64GB
- Supports triple display 1x VGA, 2 x DVI-D, dual GbEs
- Supports RAID 0, 1, 5, 10, USB 3.0

OS Support



ACP-4340 with PCE-7129 and PCE-5B13-08A1E

6th Generation Intel® Core™ i 4U Rackmount System with up to 12 Expansions



ACP-4340

- Supports Micro-ATX/ATX motherboard or PICMG backplane with up to 14 slots
- Shock-resistant disk drive bay holds four hot-swap 3.5" and 2.5" SAS/SATA disk trays, one slim optical disk drive, and one 2.5" internal drive

- Dual front USB 3.0 ports
- Front-accessible system fan without opening top cover for easy maintenance
- LED indicators and alarm notification for system fault detection

PCE-5B13-08A1E

- PICMG 1.3 BP for 14-slot chassis
- Segments: 1
- PCI slot: Eight 32/33
- PCIe slot: One x16; Three x1

PCE-7129

- Intel® Xeon E3-1200v5 series, Core™ i7/i5/i3 /Celeron/Pentium processors with C236 chipset
- Dual Channel (ECC/Non-ECC) DDR4 1866/2133 up to 32 GB
- Supports triple display 1 x VGA, 2 x DVI-D
- Supports M.2, USB 3.0, SATA3.0, RAID 0, 1, 5, 10, dual GbEs

OS Support



CompactPCI System

MIC-3100 - A Highly Robust IPC Designed for Extreme Environments

The Perfect Combination of Robust Design and Cost Efficiency



Advantech is proud to present a whole new generation of industrial computer - MIC-3100 series. This platform has highly robust structure; by using CPCI interface it's given great ventilation and anti-vibration attributes. The MIC-3100 also supports front hot-swap function which makes card switching and maintenance a lot easier. In order to ensure a high degree of compatibility and lower the investment cost, the MIC-3100 follows the common PICMG 2.x open architecture standard. The above specifications make the MIC-3100 a truly robust computing platform for extreme working environments.



European Card Type

- Highly efficient cooling
- Anti-seismic design
- EMC certification compliance



Hard Metric Pin Connectors

- Air-tight seal connector design
- Antiseptic connector design
- Great system reliability



Supports PCI and CPCI Interfaces

- High Compatibility
- Easy to integrate



Modular Design

- Front hot-swap enabled
- Easy maintenance
- Great expandability



PICMG 2.x Open Standard

- Easy for integration
- Complies with international standards



Low-Noise Operation

- 40dB Ultra low system noise



Automobile Parts Manufacturer: Chief Engineer

The MIC-3100 series' front hot-swap function makes maintenance a lot easier. The probability of facility malfunction is significantly lowered and the production efficiency is raised by 90%.



In-Vehicle Testing Equipment: System Engineer

Traditional vehicle computers often confront unexpected situations while in motion. The MIC-3100 is compatible with both CPCI & PXI interfaces which ensures stability even during rough journeys.



Steel Rolling Production: Onsite Operator and Equipment Engineer

Traditional IPC's PCI card interface often rusts in harsh environments and causes control malfunction or data reception error. The MIC-3100's CPCI interface has strong ability to withstand harsh environments.



Simulation Training Devices: Field Devices Lecturer

It's hard to swap cards installed in traditional IPC chassis and maintenance work is another difficulty. After replacing with the MIC-3100, its strong solid-joint design perfectly overcomes all the problems.



Model Name		MIC-3106-00	MIC-3111-00	MIC-3121-00
Power Type		ATX		
Input Voltage		100 - 240 VAC		100 - 127 VAC 200 - 240 VAC
Wattage		180W		300W
On/Off Switch		Lockable Toggle Switch		
System Slot		1, on the right		
Peripheral Slot		2 Slots	7 Slots	7 Slots
PCI Bus		32-bit 33MHz		32-bit 33MHz
Dimensions (W x H x D mm)		134 x 177 x 238	234 x 177 x 258	482 x 177 x 310
Weight (kg)		4.33	6.14	9.65
Temperature	Operating	0 ~ 50 °C		
	Non-Operating	-20 ~ 60 °C		
Humidity (non-condensing)	Operating	10 ~ 85% @ 40 °C		
	Non-Operating	10 ~ 85% @ 40 °C		
Vibration (5 ~ 500 Hz)	Operating	2Grms (without HDD)		
	Non-Operating	2G		
Shock (11ms)	Operating	10G		
	Non-Operating	30G		
Regulatory Compliance		CE, FCC, CCC, UL, RoHS, BSMI PICMG 2.0 Rev. 3.0		

Automotive Testing and Measurement Packages

Automotive Sensor Testing Package



Item	Specification	Package Features
MIC-3714	3U, 30MS/s, 12bit, 4 channels simultaneous AI card	Automotive sensors are the key components and information sources of automotive electronic control system, and also among the core contents of automotive electronics technology. They are divided into several parts: the engine control system sensors, chassis control sensors, body control sensors, and so on. Through synchronized measurement mechanism, we can get basic test indicators of auto sensors: input voltage, output voltage, output leakage voltage, input current, output current of sensors, and so on.
MIC-3106-L2-AE	CPCI Chassis 4U, 3 slots, 180W	
	CPCI bus CPU card D525 CPU/2G RAM	

Automotive Electronics Testing Package



Item	Specification	Package Features
MIC-3756-BE	3U, 32 channels isolated DI/O card	Dashboard with its features of high reliability and precision becomes a distinct trait of the automotive industry, resulting in diversified signal forms. The dashboard mostly uses CAN bus communication interface, which can achieve complicated tests that need a variety of measurement techniques and methods to coordinate. Equipments must have a high degree of integration for users to easily replace the measurement modules, coupled with the CAN bus data communication for data comparison. Through a front accessible hot-swap enabled high-resolution multifunctional acquisition card, and a isolated CAN bus communication card, replacement process of measurement modules can be done quickly and work well with the devices under test.
MIC-3680	3U, CAN bus 2 ports communication card	
MIC-3111-L2-AE	CPCI Chassis 4U, 7 slots, 180W	
	CPCI bus CPU card D525 CPU/2G RAM	

Automotive Brake System Testing Package

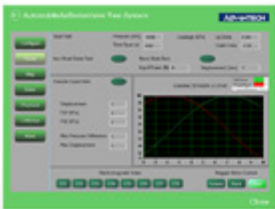

Item	Specification	Package Features
MIC-3756-BE	3U, 32 channels isolated DI/O card	Braking performance is very important for a car, related to a vehicle's safety and reliability. Therefore, the tests of various components within the brake system are also very important, generally require testing on the reaction time of four-channel protection valve, pressure distribution in each branch of brake and hand-brake valves, and air brake system. Through a high-resolution multifunctional data acquisition card with an isolated DI/O card, a sound test environment is built, ensuring reliability and easy replacement, which fully meets different needs of process designs.
MIC-3716	250KS/s, 16 bit 16 channels high-res multifunction card	
MIC-3111-L2-AE	CPCI Chassis 4U, 7 slots, 180W	
	CPCI bus CPU card D525 CPU/2G RAM	

Extensive PCI/PCIE DAQ Card Range Satisfies all Equipment Testing and Measurement Demands

New Generation Interface for DAQ: PCI Express

PCI Express is a computer expansion bus standard designed to replace the older PCI bus standards. The PCI Special Interest Group (PCI-SIG) preserved and developed PCI specification to become the new standard PCI Express from 2003. PCI Express delivers 30 times the bandwidth of PCI bus, with a per-lane data rate 250 MB/s and a transfer rate of 2.5 GT/s. This new generation interface features high speed point-to-point architecture, high throughput performance, software backward compatibility, I/O simplification, etc. Following this technology trend, Advantech offers a series of PCI Express data acquisition cards with the same development software as PCI card, to satisfy different automation needs.

Key Features

BoardID Switch

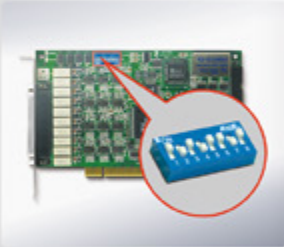

BoardID DIP switches help define each card's unique identity when multiple identical PCI cards are installed in the same computer. With the correct BoardID switch settings, you can easily identify and access each card during hardware configuration and software programming.

Auto Calibration

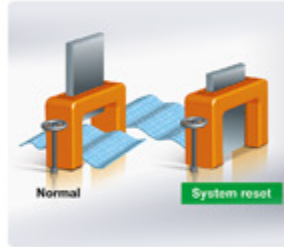

The built-in auto-calibration circuitry corrects gain and offset errors in analog input and analog output channels thereby eliminating the need for external equipment and user adjustments.

High Density

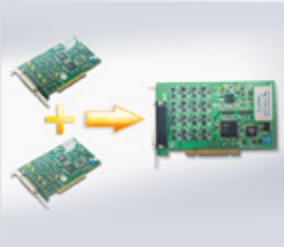

High density means there are many input/output functions in one PCI card. In the past, customers were forced to buy more than one card to fulfill their application, but now just one card can achieve their goals. The biggest advantage of this feature is that it saves space, allowing more efficient installation.

Retains Output Values After System Reset



When the system is hot reset (power is not shut off), Advantech DAQ cards with this function can either retain the last digital (or analog) output values, or return to its default configuration. This eliminates danger caused by misoperation during unexpected system reset.

Direct Memory Access

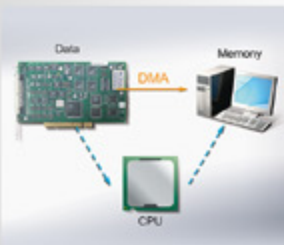

A method of transferring data from or to memory at a high rate without involving the CPU. DMA is the hardware/software technique that allows the highest speed transfer of data, to or from RAM. DMA can provide the means to read or write data at precise times without restricting the microprocessor's tasks.

PCIE-1810

800 KS/s, 12-bit, 16-ch PCI Express Multifunction Card



Features

- 16 analog inputs, up to 800 KS/s, 12-bit resolution
- 2 analog outputs, up to 500 KS/s, 12-bit resolution
- Support for digital trigger and analog trigger (AI only)
- 24 programmable digital I/O lines
- Two 32-bit programmable counter/timers
- Onboard FIFO memory (4 K samples)
- Automatic channel/ gain scanning
- LabVIEW driver support

Ordering Information

- PCIE-1810 800 KS/s, 12-bit Multifunction Card

Accessories

- PCL-10168H-1E 68-pin SCSI shielded cable with noise rejection (1 m)
- PCL-10168H-2E 68-pin SCSI shielded cable with noise rejection (2 m)
- PCL-10168-1E 68-pin SCSI shielded cable (1 m)
- PCL-10168-2E 68-pin SCSI shielded cable (2 m)
- ADAM-3968-AE 68-pin DIN-rail SCSI wiring board

OS Support



PCIE-1816

1 MS/s, 16-bit, 16-ch PCI Express Multifunction DAQ Card



Features

- 16-bit, 16-ch analog inputs, 1 MS/s (single-channel) and 500 kS/s (multiple-channel)
- 16-bit, 2-ch analog outputs, 3 MS/s
- Supports both digital and analog triggers (16 bit)
- 5 V/TTL DI/O (24 inputs/outputs; direction programmable)
- 32-bit, 2-ch counter, up to 10 MHz
- Capable of event counting, frequency and pulse width measurement, pulse-train generation, and PWM output
- Supports pattern match and change of status DI interrupts
- LabVIEW driver support

Ordering Information

- PCIE-1816 1 MS/s, 16-bit multifunction card
- PCL-10168H 68-pin SCSI shielded cable with noise rejection (1/2 m)
- PCL-10168 68-pin SCSI shielded cable (1/2 m)
- ADAM-3968 68-pin DIN-rail SCSI wiring board

OS Support



PCIE-1812

250 kS/s, 16-bit, 8-ch, Simultaneous Sampling Multifunction PCI Express DAQ Card



Features

- 8 differential simultaneous sampling analog inputs, up to 250 kS/s, 16-bit resolution
- 2 analog outputs, up to 3 MS/s, 16-bit resolution
- Full auto-calibration
- 2 analog triggers and 2 digital triggers for AI/O
- 32 programmable DI/Os with interrupt functions
- Four 32-bit programmable counters/ timers/ encoders
- Board ID switch
- LabVIEW driver support

Ordering Information

- PCIE-1812 250 kS/s, 16-bit, 8-ch simultaneous sampling multifunction card

Accessories

- PCL-101100-1E PCL-101100-1E 100-pin SCSI shielded cable (1 m)
- PCL-101100-2E PCL-101100-2E 100-pin SCSI shielded cable (2 m)
- ADAM-39100-AE ADAM-39100-AE 100-pin DIN-rail SCSI wiring board

OS Support



PCI/PCI Express Cards

PCIE-1756/PCI-1756

64-ch Isolated Digital Input/Output PCI Express/PCI Card



Features

- Wide input (10 ~ 30 VDC) and output (5 ~ 40 VDC) ranges
- High sink current on isolated output channels (500mA max./ch)
- Supports pattern match and change of status DI interrupts
- High over-voltage protection (70 VDC)
- 2,500 VDC isolation protection
- LabVIEW driver support

Ordering Information

- PCI-1756 64-ch isolated digital I/O PCI card
- PCIE-1756 64-ch isolated digital I/O PCI express card
- PCL-10250 100-pin SCSI to dual 50-pin SCSI cable (1/2 m)
- ADAM-3951 50-pin DIN-rail wiring board with LED indicators
- PCL-101100M-3 100-pin SCSI to 100-pin SCSI cable (3 m)
- ADAM-39100 100-pin DIN-rail wiring board

OS Support



PCI-1710U/UL/HGU

100 kS/s, 12-bit, 16-ch PCI Multifunction Card



Features

- 16 single-ended/8 differential 12-bit analog inputs at 100 kS/s
- 12-bit dual-channel analog outputs with static updates (for PCI-1710 and PCI-1710HGU only)
- 5 V/TTL DI/O (16 inputs and 16 outputs)
- 16-bit single-channel counter, up to 10 MHz
- Supports event counting and pulse train output
- LabVIEW driver support

Ordering Information

- PCI-1710U 100 kS/s, 12-bit multifunction card
- PCI-1710UL 100 kS/s, 12-bit multifunction card without analog output
- PCI-1710HGU 100 kS/s, 12-bit high-gain multifunction card (for precise small-signal measurements)
- PCLD-8710 DIN-rail wiring board with CJC
- PCL-10168 68-pin SCSI shielded cable (1/2 m)
- ADAM-3968 68-pin DIN-rail SCSI wiring board

OS Support



PCI-1716/L

250 kS/s, 16-bit, 16-ch PCI Multifunction Card



Features

- 16 single-ended/8 differential 16-bit analog inputs at 250 kS/s
- 16-bit, 2-ch analog outputs with static updates (PCI-1716 only)
- 5 V/TTL DI/O (16 inputs and 16 outputs)
- 16-bit, single-channel counter, up to 10 MHz
- Supports event counting and pulse train output
- LabVIEW driver support

Ordering Information

- PCI-1716 250 kS/s, 16-bit multifunction card
- PCI-1716L 250 kS/s, 16-bit multifunction card without analog output
- PCLD-8710 DIN-rail wiring board with CJC
- PCL-10168 68-pin SCSI shielded cable (1/2 m)
- ADAM-3968 68-pin DIN-rail SCSI wiring board

OS Support



PCI-1760U

8-ch Relay and 8-ch Isolated Digital Input Universal PCI Card with 10-ch Counter/Timer



Features

- 2 x Form C and 6 x Form A relay channels
- Contact rating of 1 A @ 125 VAC, 2 A @ 30 VDC
- LED indicators show activated relays
- Programmable DI filter
- 2,500 VDC isolation protection for DI
- DI supports both wet and dry contact
- Supports pattern match and change of status interrupt for DI
- 16-bit, 8-ch counter at up to 500 Hz for event counting
- 2-ch PWM output
- LabVIEW driver support

Ordering Information

- PCI-1760U 8-ch relay and 8-ch isolated DI PCI card
- PCL-10137 DB37 Cable (1/2/3 m)
- ADAM-3937 DB37 DIN-rail wiring board

OS Support



PCI-1784

4-ch, 32-bit Encoder Counter Universal PCI Card with 8-ch Isolated Digital I/O

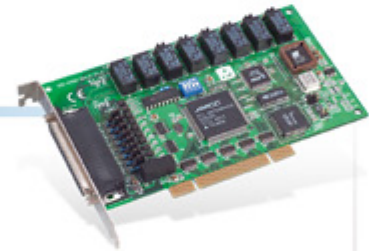

Features

- 4 x 32-bit encoder counters
- Supports single-ended and differential inputs
- Quadrature (x1, x2, x4), pulse/direction, and up/down counting modes
- 2,500 VDC optical isolation protection
- 4-stage digital filter with selectable sampling rate
- 8-bit timer with wide range time-base selector on board
- Multiple interrupt sources for precision application
- 4 x isolated digital inputs and 4 x isolated digital outputs
- Board ID™ switch
- LabVIEW driver support

Ordering Information

- PCI-1784U 4-ch encoder counter universal PCI card
- PCL-10137H-3E High-speed DB37 cable (3 m)
- ADAM-3937 DB37 DIN-rail wiring board

OS Support



PCIE-1680

2-Port CAN-Bus PCIE card with Isolation Protection



Features

- Compliant with PCIe Bus revision 1.2
- Supports simultaneous operation of two CAN networks
- High-speed data transmissions, up to 1 Mbps
- 16 MHz CAN controller frequency
- 2,500 VDC optical isolation protection
- Automatic I/O address assignment by PCI PnP
- Transmit/Receive status LED indicators
- Windows DLL library and examples included

Ordering Information

- PCIE-1680-AE 2-port CAN-bus PCIE card with isolation protection

OS Support



Advantech USB DAQ Modules

Portable, Robust, and Versatile USB DAQ Modules

Advantech's USB DAQ modules are known for their user-friendly design and ability to replace traditional serial and parallel devices as they eliminate the need for an external power and allow hot swapping. Through the Advantech USB DAQ series, users can easily upgrade their computing platforms with cutting edge technologies and realize cost-effective maintenance while allowing the data acquisition devices to operate as usual. By adding industrial-grade features, including lockable cables, multiple mounting methods and advanced detection functions, Advantech's USB data acquisition devices are a great fit for any industrial need.

Key Feature



Lockable USB Cable

Reliable connections are critical to automation control and online production. While the standard USB cable is designed for convenience, Advantech provides lockable USB cables to prevent the cable from being unplugged accidentally.



High-Speed Data Transfer Rate

Advanced data acquisition functions can be accomplished. Up to 200 kS/s sampling rate, 16-bit resolution, 16-ch analog input, 48-ch digital I/O specifications, as well as interrupt, event counter, and pulse width modulation (PWM) functions are available on Advantech's USB data acquisition modules.



Detachable Screw Terminal with On-Module Pin Assignment Index

Saving space & money is the main benefit of using detachable screw terminals. Budgets can be saved by not having to buy additional cables and/or wiring boards, and extra space can be saved as well. Furthermore, Advantech's on-module pin assignment simplifies maintenance efforts and reduces incorrect connections that can cause damage to the system.

USB-4711A

150 kS/s, 12-bit, 16-ch Multifunction USB Module

Features

- 16 single-ended/8 differential 12-bit analog inputs at 150 kS/s
- 12-bit, 2-ch analog output with static updates
- 5 V/TTL DI/O (8 inputs and 8 outputs)
- 32-bit, single-channel counter, up to 1 kHz
- Supports event counting and frequency measurements
- 1 x lockable USB cable for connection security
- LabVIEW driver support

Ordering Information

- USB-4711A 150 kS/s, 12-bit, 16-ch multifunction USB module
- 1960004544 Wall mount bracket
- 1960005788 VESA mount bracket

OS Support



USB-4716

200 kS/s, 16-bit, 16-ch Multifunction USB Module

Features

- 16 single-ended/8 differential 16-bit analog inputs at 200 kS/s
- 16-bit, 2-ch analog output with static updates
- 5 V/TTL DI/O (8 inputs and 8 outputs)
- 32-bit, single-channel counter, up to 1 kHz
- Supports event counting and frequency measurements
- 1 x lockable USB cable for connection security
- LabVIEW driver support

Ordering Information

- USB-4716 200 kS/s, 16-bit, 16-ch multifunction USB module
- 1960005788 Wall mount bracket
- 1960005788 VESA mount bracket

OS Support



USB-4718

8-ch Thermocouple Input USB Module with 8-ch Isolated Digital Input

Features

- 8 x 16-bit differential analog inputs at 10 S/s
- Supports voltage, current, and thermocouple inputs
- 8-ch isolated digital inputs and 8-ch isolated digital outputs
- 2,500 VDC optical isolation protection
- 1 x lockable USB cable for connection security
- LabVIEW driver support

Ordering Information

- USB-4718 8-ch thermocouple input USB module
- 1960004544 Wall mount bracket
- 1960005788 VESA mount bracket

OS Support



USB Modules

USB-4750

32-ch Isolated Digital I/O USB Module

Features

- 16-ch isolated digital inputs and 16-ch isolated digital outputs
- Isolated DO current (100 mA max./channel, 1.1 A max./total)
- Supports DI interrupt
- 32-bit, 2-ch isolated counter, up to 8 MHz
- Supports event counting and frequency measurements
- 2,500 VDC isolation protection
- LabVIEW driver support

OS Support



Ordering Information

- | | |
|--------------|---------------------------------------|
| • USB-4750 | 32-ch isolated digital I/O USB module |
| • 1960004544 | Wall mount bracket |
| • 1960005788 | VESA mount bracket |

USB-4751/L

48/24-ch Digital I/O USB Module

Features

- USB-4751L: 24-ch TTL DI/O
- USB-4751: 48-ch TTL DO
- Supports both dry and wet contact
- Supports DI interrupt
- 32-bit, 2-ch counter, up to 8 MHz
- Supports event counting, frequency measurements, pulse train, and PWM output
- 1 x lockable USB cable for connection security
- LabVIEW driver support

OS Support



Ordering Information

- | | |
|--------------|------------------------------|
| • USB-4751 | 48-ch digital I/O USB module |
| • USB-4751L | 24-ch digital I/O USB module |
| • 1960004544 | Wall mount bracket |
| • 1960005788 | VESA mount bracket |

USB-4761

8-ch Relay and 8-ch Isolated Digital Input USB Module

Features

- LED indicators show activated relays
- 8 x Form C relays
- Contact rating of 0.25 A @ 250 VAC, 2 A @ 30 VDC
- 8-ch isolated DI with 5 ~ 30 VDC range
- Supports DI interrupt
- 2,500 VDC protection for isolated digital input channels
- 1 x lockable USB cable for connection security
- LabVIEW driver support

OS Support



Ordering Information

- | | |
|--------------|---|
| • USB-4761 | 8-ch relay and 8-ch isolated digital input USB module |
| • 1960004544 | Wall mount bracket |
| • 1960005788 | VESA mount bracket |

USB-4620

5-Port Full-Speed Isolated USB 2.0 Hub



Features

- 5 x downstream USB 2.0 ports
- Compatible with USB 2.0 (full speed), 1.1, and 1.0
- Up to 12 Mbps data transfer rate
- 3,000 VDC isolation protection for every downstream port
- Suitable for DIN-rail mounting
- 1 x lockable USB cable
- 10 ~ 30 VDC power input (power adapter not included)

Ordering Information

- | | |
|--------------------|---|
| • USB-4620 | 5-port full-speed isolated USB 2.0 hub |
| • PWR-242 | DIN-rail power supply |
| • 1960004544 | Wall mount bracket |
| • 1960005788 | VESA mount bracket |
| • USB-LOCKCABLE-AE | Lockable USB 2.0 cable (1.8 m) with screw kit |

OS Support



USB-4630

4-Port SuperSpeed Isolated USB 3.0 Hub



Features

- 2,500 VDC voltage isolation for upstream ports
- 4 x downstream SuperSpeed USB 3.0 ports
- Compatible with 10 ~ 30 V DC external power or USB bus power
- Suitable for DIN-rail mounting
- LED indicators show power status and downstream port speed
- 1 x lockable USB 3.0 cable
- Data transfer rate of up to 5 Gbps
- Compatible with SuperSpeed USB 3.0

Ordering Information

- | | |
|--------------|--|
| • USB-4630 | 4-port SuperSpeed isolated USB 3.0 hub |
| • PWR-242 | DIN-rail power supply |
| • 1960004544 | Wall mount bracket |
| • 1960005788 | VESA mount bracket |

OS Support



Dimensions

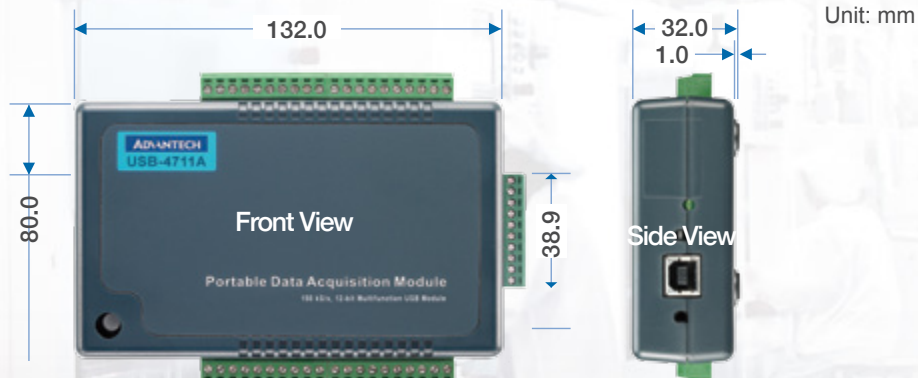

Ultra-High Performance PCI Express Instrument Cards

Powerful PCI Express Multifunction Data Acquisition Card

Advantech produces multifunction DAQ cards that combine high-performance signal measurements, arbitrary wave generation, digital I/O, and counter functions. All DAQ cards are equipped with both a digital trigger and a high-resolution analog trigger that enable users to easily and flexibly define when to start or stop data acquisition.

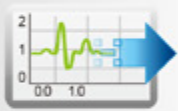

Waveform Generator



16-bit Analog Trigger



Double Clock



500ks/1MS Sample Rate



Automatic Calibration

PCI Express Dynamic Signal Analyzer

PCIE-1802 provides highly precise 24-bit resolution and is the ideal solution for sound, audio, and vibration measurement, as well as machine monitoring. The high-density 8-channel analog inputs can be directly connected to IEPE and TEDS sensors, and conduct simultaneous data acquisition at a sampling rate of 256 kS/s with an anti-alias filter.

PCIE-1802

24-bit, 8-ch PCI Express Dynamic Signal Analyzer

Features

- 24-bit, 8-ch simultaneous analog inputs, 216 kS/s per channel
- 6 gains settings with ± 0.2 to ± 10 V input ranges
- Supports IEPE smart sensors
- Channel-specific configurable 0 ~ 10 mA excitation settings
- Channel-specific configurable AC/DC coupling settings
- Digital and analog triggers (24-bit)
- Anti-aliasing filter
- Onboard FIFO size (4096 samples)
- DC offset null adjustment
- 5 V/TTL DI/O (1 input and 1 output)
- LabVIEW driver support

Ordering Information

- PCIE-1802-AE 20-pin DIN-rail HDMI cable wiring board for PCIE-1802 and PCIE-1840
- PCLD-8840-AE 216 kS/s, 24-bit dynamic signal analyzer card
- PCL-108BNC-50E Mini SCSI to 8-BNC cable
- PCL-10119-1E HDMI cable



OS Support



High-Speed PCI Express Digitizer

The PCIE-1840 can perform extremely high speed measurement with high resolution 16-bit. Its four channels can all acquire signals with 125 MS/s sampling rate, or user can cascade all channels to single channel, that sampling rate can rise up to 500 MS/s. With its re-trigger function and time-stamped ability, user can get relative timing information when performing measurement.

With Advantech's 8TB disk array system, 2 hours of continuous 1GB/s data storage can be achieved.

PCIE-1840

4-ch 16-bit 125 MS/s High Speed PCI Express Digitizer



Features

- 16-bit, 4-ch simultaneous analog outputs, 125 MS/s per channel
- Cascade channels enable higher sampling rates, 250 MS/s (2 channels) and 500 MS/s (single channel only)
- Non-stop data streaming capabilities
- 2 GB of on-board memory
- On-board anti-aliasing filter
- Selectable input impedance (1 M or 50 Ohm)
- LabVIEW driver support

Ordering Information

- PCIE-1840 125 MS/s, 16-bit, 4-ch high-speed PCI express digitizer

OS Support



PCIE-1840 High-Speed Storage Solution

Advantech's high-speed storage solution is a big data storage solution built on a PCIE-1840 high-speed data acquisition card. PCIE-1840 can capture 500 MB of 16-bit data per second, which, when converted into a data stream, can be stored on the hard drive at 1 Gbyte per second. PCIE-1840 provides highly efficient data sampling and data access capabilities for long-term and high-speed data sampling and analysis applications. The system is equipped with an advanced RAID card, as well as a hard disk array composed of eight hard disks. Furthermore, the software optimizes data exchange processes and can support up to 2 hours of uninterrupted data storage under even the most high-speed data acquisition rate. With the Advantech high-speed storage solution, researchers can focus on acquiring and analyzing data without worrying about storage. Additionally, they have instant access to abundant continuous sample data, thereby eliminating the risk of sampling bias due to limited storage capacity. Researchers can obtain reliable input signals for verifying the stability of various parameters, such as RF, microwave frequency, and radar parameters.



Regional Service & Customization Centers

China	Taiwan	Netherlands	Poland	USA
Kunshan 86-512-5777-5666	Taipei 886-2-2792-7818	Eindhoven 31-40-267-7000	Warsaw 00800-2426-8080	Milpitas, CA 1-408-519-3898

Worldwide Offices

Greater China

China	
Toll Free	800-810-0345
Beijing	86-10-6298-4346
Shanghai	86-21-3632-1616
Shenzhen	86-755-8212-4222
Chengdu	86-28-8545-0198
Hong Kong	852-2720-5118

Taiwan	
Toll Free	0800-777-111
Neihu	886-2-2792-7818
Xindian	886-2-2218-4567
Taichung	886-4-2329-0371
Kaohsiung	886-7-229-3600

Asia Pacific

Japan	
Toll Free	0800-500-1055
Tokyo	81-3-6802-1021
Osaka	81-3-6802-1021

Korea	
Toll Free	080-363-9494
Seoul	82-2-3663-9494

Singapore	
Singapore	65-6442-1000

Malaysia	
Kuala Lumpur	60-3-7725-4188
Penang	60-4-537-9188

Thailand	
Bangkok	66-2-248-3140

India	
Bangalore	91-80-2545-0206
Pune	91-20-3948-2075

Indonesia	
Jakarta	62-21-751-1939

Australia	
Toll Free	1300-308-531
Melbourne	61-3-9797-0100
Sydney	61-2-9476-9300

Europe

Germany	
Toll Free	00800-2426-8080
Munich	49-89-12599-0
Düsseldorf	49-2103-97-855-0

France	
Paris	33-1-4119-4666

Italy	
Milano	39-02-9544-961

Benelux & Nordics	
Breda	31-76-523-3100

UK	
Reading	44-0-118-929-4540
Newcastle	44-0-191-262-4844
London	44-0-870-493-1433

Poland	
Warsaw	48-22-31-51-100

Russia	
Moscow	8-800-555-01-50
St. Petersburg	8-800-555-81-20

Americas

North America	
Toll Free	1-888-576-9668
Cincinnati	1-513-742-8895
Milpitas	1-408-519-3898
Irvine	1-949-420-2500

Brazil	
Toll Free	0800-770-5355
São Paulo	55-11-5592-5355

Mexico	
Toll Free	1-800-467-2415
Mexico City	52-55-6275-2727

ADVANTECH

Enabling an Intelligent Planet

www.advantech.com

Please verify specifications before quoting. This guide is intended for reference purposes only.

All product specifications are subject to change without notice.

No part of this publication may be reproduced in any form or by any means, electronic, photocopying, recording or otherwise, without prior written permission of the publisher.

All brand and product names are trademarks or registered trademarks of their respective companies.

© Advantech Co., Ltd. 2016



860000256